

NOTES:

1. SEDIMENT DEPOSITS APPROXIMATELY 1/3 THE HEIGHT OF THE BARRIER MUST BE REMOVED WITHIN 24 HOURS OF DISCOVERY.
2. ADD METAL WIRE MESH/FENCE TO DOWNHILL SIDE OF SILT FENCE FOR ADDITIONAL SUPPORT IN AREAS OF CONCENTRATED FLOW AS NEEDED.

HAND INSTALLED (HI) SILT FENCE INSTALLATION

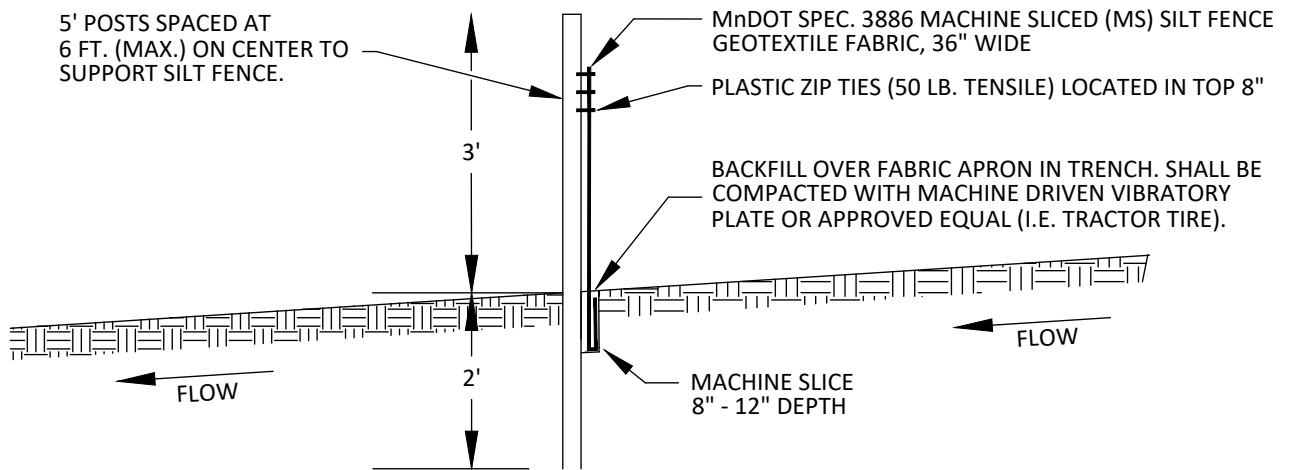

NOTES:

1. SEDIMENT DEPOSITS APPROXIMATELY 1/3 THE HEIGHT OF THE BARRIER MUST BE REMOVED WITHIN 24 HOURS OF DISCOVERY.
2. ADD METAL WIRE MESH/FENCE TO DOWNHILL SIDE OF SILT FENCE FOR ADDITIONAL SUPPORT IN AREAS OF CONCENTRATED FLOW AS NEEDED.

MACHINE SLICED (MS) SILT FENCE INSTALLATION