

ISOMETRIC

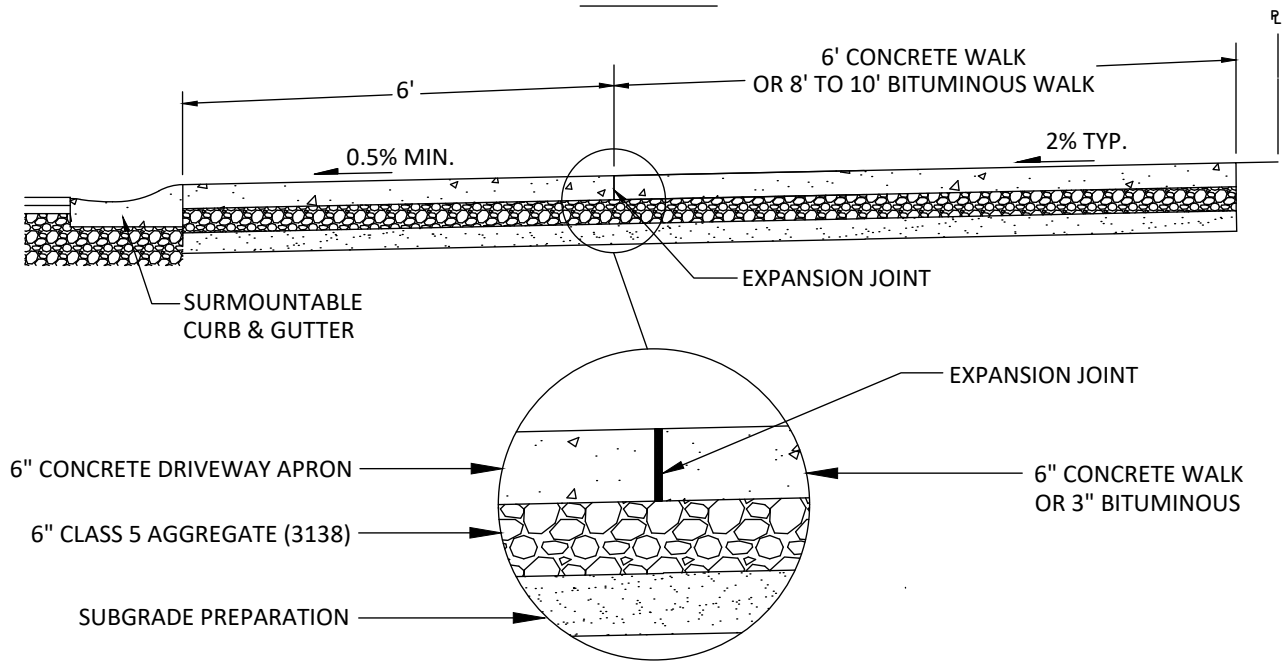

SECTION

NOTES:

1. CONCRETE PANELS SHALL NOT EXCEED 9' IN ANY DIRECTION.
2. POUR CURB, SIDEWALK, AND DRIVEWAY SEPARATELY.
3. DRIVEWAY GRADE AT PROPERTY LINE SHALL BE A MINIMUM OF 4 IN ABOVE THE FLOWLINE.